

21309 EK

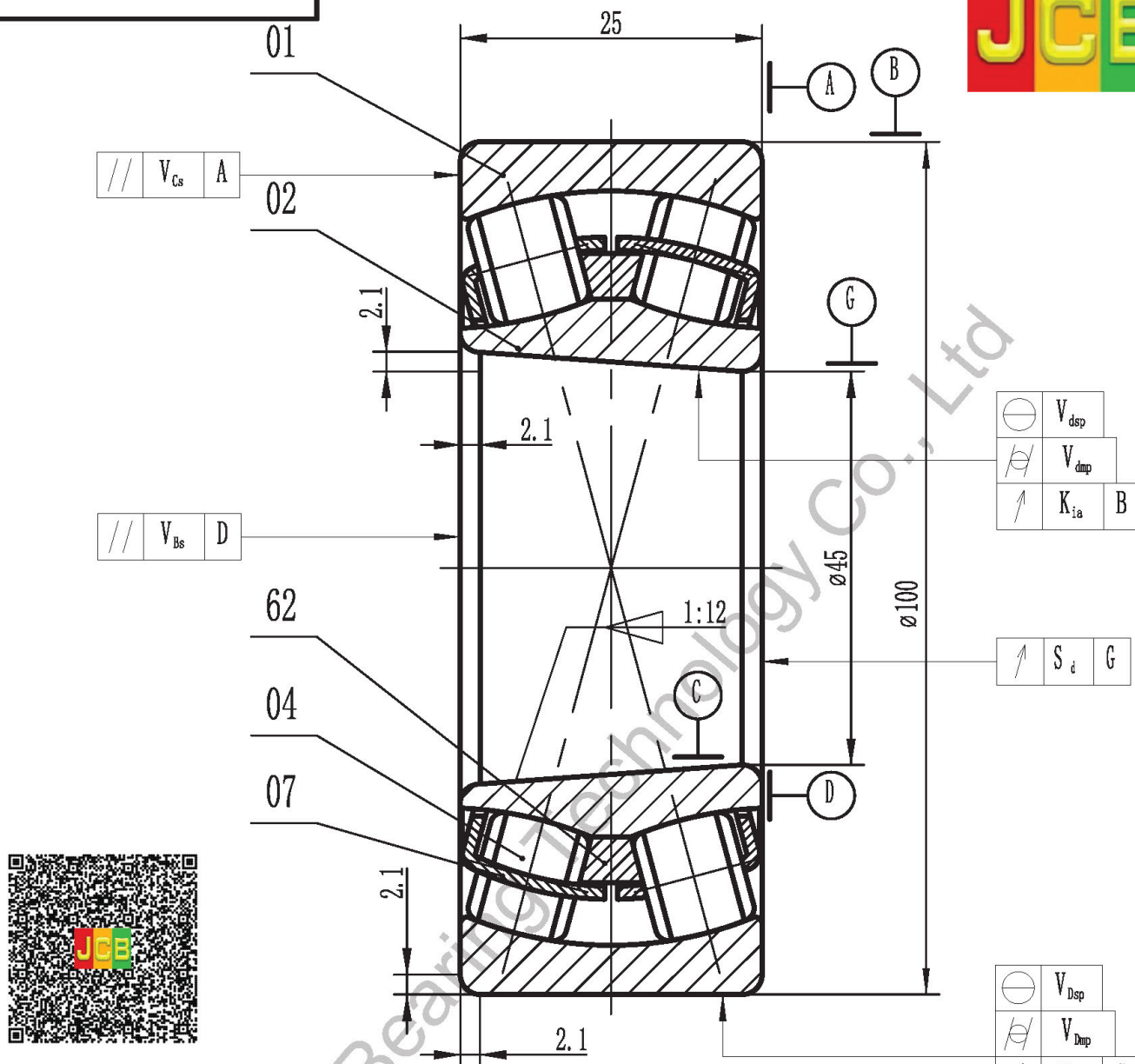

1. Tolerance of running accuracy are according to relevant state standard;
2. The value of the basic group of radial clearance: min 0.100 max 0.135;
3. Rated load:  $C_r=640$  kN  $C_{or}=740$  kN.

| 62  | Guide ring |     | Steel 20—GB699                     |             |       |        |
|-----|------------|-----|------------------------------------|-------------|-------|--------|
| 07  | Cage       |     | Steel St 52—EN 10025:1990 + A:1993 |             |       |        |
| 04  | Roller     |     | Steel 100Cr6—ISO 683-17:1999       |             |       |        |
| 02  | Inner ring |     | Steel 100Cr6—ISO 683-17:1999       |             |       |        |
| 01  | Outer ring |     | Steel 100Cr6—ISO 683-17:1999       |             |       |        |
| No. | Name       | Qty | Material                           | Unit        | Total | Remark |
|     |            |     |                                    | Weight (kg) |       |        |

Luoyang JCB Bearing Technology Co., Ltd  
 Contact information  
 Company Address : No. 285, Fenghua road,  
 Luoyang, Henan, China.  
 Postal code : 471000  
 Phone : 86-379-68611678  
 Fax : 86-379-68611679  
 E-mail: sales@jcb-bearing.com  
 Reserved E-mail: sales@sphericalrollerbearing.net  
 Website: www.jcb-bearing.com  
 www.sphericalrollerbearing.net

## Spherical Roller Bearing

21309 EK

Weight (kg) Scale

S

Total page 6 Page No. 1

Luoyang JCB Bearing Technology Co., Ltd